

3-Way Safety Block DSV

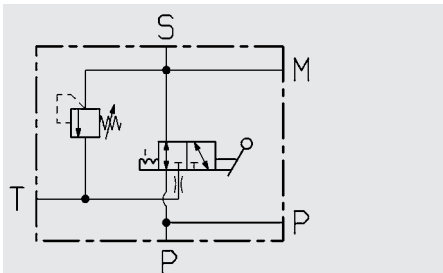

DSV 10 - M

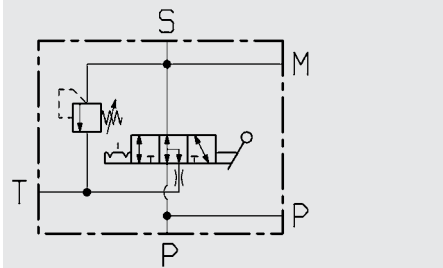

DSV 10 - M - T-ball

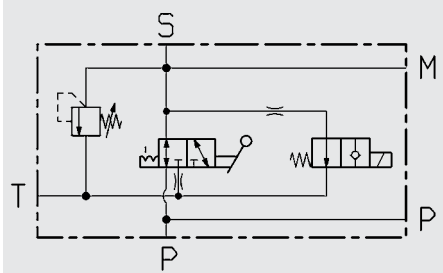

DSV 10 - EY

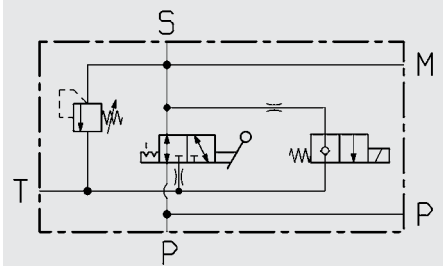

DSV 10 - EZ

PN up to 350
DN 10

1. DESCRIPTION

1.1. GENERAL

The 3-way safety block is used to shut off and discharge hydraulic accumulators or consumers. It complies with relevant safety standards in accordance with accident prevention regulations (UVV (VBG 17)), safety regulations to DIN 24552, pressure vessels regulations (Druckbeh.V) and technical regulations on pressure vessels (TRB 403 and TRB 404).

The pressure relief valve can be supplied either pre-set by the manufacturer according to order, adjustable or pressure-set & lead-sealed by TÜV.

There are four different models:

- DSV 10 M
manual discharge
standard - L-ball
- DSV 10 M - T-ball
manual discharge
T-ball
- DSV 10 EY
manual /
solenoid-operated discharge
open when de-energised
- DSV 10 EZ
manual /
solenoid-operated discharge
closed when de-energised

Benefits of the accumulator block:

- Slot on the control spindle gives visual indication of the switching position
- Switching limited by means of stop pin and stop disc
- Sealing principle with floating ball, sealing on the inlet side
- Easy operation
- Two pump ports
- Optimised block design
- Minimum of space and fitting required
- All types of connection adapters for various makes and systems of accumulator
- Surface protection phosphate-plated

On request we can supply other models to cover nearly all applications, e.g. for aggressive media. Test certificates to EN 10204 and quality test certificates to DIN 55350 Part 18 can be supplied if required.

1.2. FUNCTION

When the accumulator is in operation the change-over ball valve connects the pump port with the accumulator. At the same time the accumulator is monitored for pressure via the built-in pressure relief valve.

By switching over the ball valve, the pump port is shut off leakage-free on the inlet side and the accumulator is discharged simultaneously to the tank. During switching, all three ports (P, S and T) are momentarily interconnected (negative switching overlap).

If a solenoid operated 2/2 directional poppet valve is fitted, automatic discharge is possible (e.g. in the event of a power failure or shut-down).

1.3. APPLICATION

The three-way safety block DSV is used to protect, shut-off and discharge hydraulic accumulators and consumers.

Areas of application:

- Hydraulic systems using accumulators
- Accumulator stations
- System engineering

1.4. NOTES

Ball valves are not designed to be used as flow control valves. Therefore they should always be either fully open or fully closed, to avoid damaging the sealing cups.

To ensure correct functioning, pressure and temperature specifications must be observed.

The handles are supplied loose.

Accumulator operation

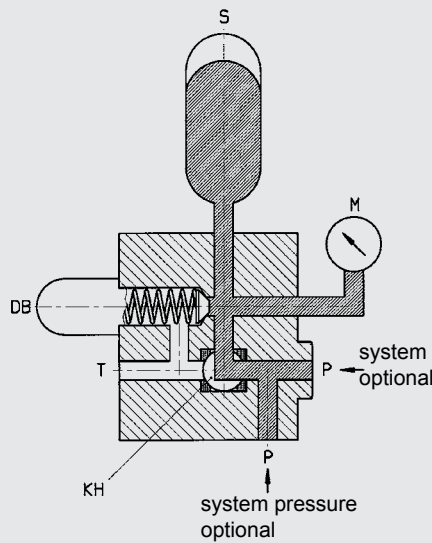

Shutting off the system pressure and simultaneously discharging the accumulator

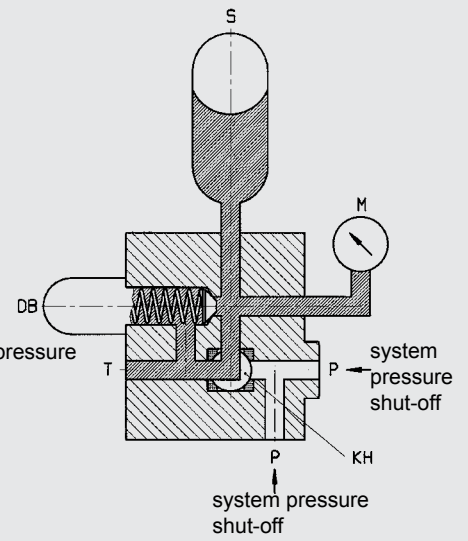

P	Pump port	S	Accumulator
KH	Change-over ball valve	DB	Pressure relief valve
M	Pressure gauge port	T	Tank port

2. SPECIFICATIONS

2.1. GENERAL

2.1.1 Designation and Symbol

3-way safety block DSV

DSV 10 - M

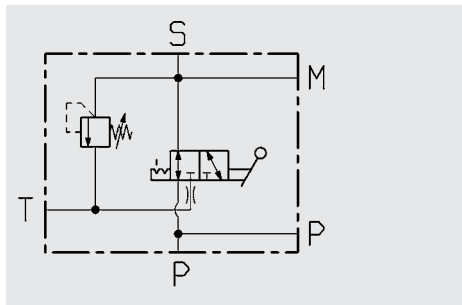

DSV 10 - M - T-ball

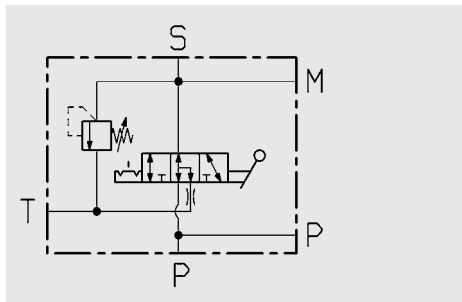

DSV 10 - EY

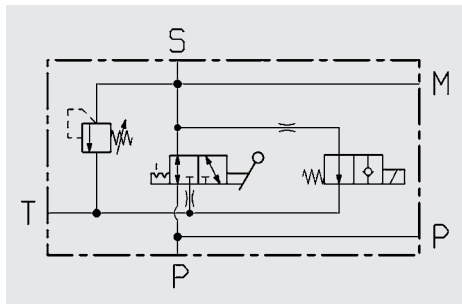

DSV 10 - EZ

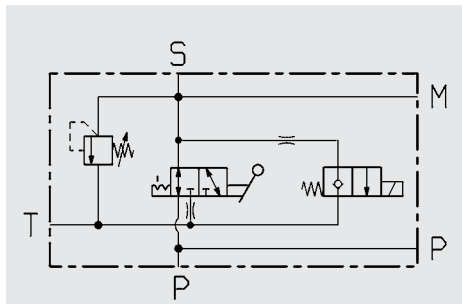

2.1.2 Model code (also order example)

DSV - 10 - M ... - 4 . 1 / 1 / X / T 100 - G 24 - Z4 - ...

3-way safety block

Nominal bore
10

Discharge

M = Manual

E = Manual / solenoid-operated

**For solenoid-operated discharge
with manual override, also indicate:**

Y = Open when de-energised

Z = Closed when de-energised

Type of pressure relief valve

4 = DB 12

2 = DB 4

0 = DBD 6 (on request)

**With/without fitted
pressure relief valve**

1 = With pressure relief valve

0 = Without pressure relief valve

Accumulator connection

1 = M 33 x 2

(M 20 x 1.5 - DBD6, on request)

Series

(determined by manufacturer)

Setting of pressure relief valve

T = TÜV certificate (pressure set & lead sealed)

V = Adjustable using tool

F = Preset by manufacturer

x = No details (for model without relief valve cartridge)

Pressure setting

... = Customer-specified opening pressure

xxx = No details (for model without relief valve cartridge)

Pressure setting range

DB 4 – 100 bar

DB 12 – 150 bar

DB 4 – 200 bar

DB 12 – 250 bar

DB 4 / 12 – 350 bar

Type of voltage for solenoid (see 2.3.2)

G = DC

W = AC

Nominal voltage for solenoid (see 2.3.2)

24 = 24 Volt DC (for type G voltage)

230 = 230 Volt 50/60 Hz AC (for type W voltage)

Type of connection for solenoid

Z4 = Connector to DIN 43650 - AF2 - PG11

Supplementary details

T-Ball = Ball bore (180° switch)

FKM (Viton) = O-ring seal

When ordering please quote Part No. (see Table 2.1.3)

Delivery is longer for non-standard models.

2.1.3 Standard models

Nominal bore / Type	Pressure relief valve	Order No. = Part No.	Weight [kg]
DSV - 10 - M - 2.0/1/X/XXXX	without DB 4	555998	2.5
DSV - 10 - M - 2.1/1/X/T100	DB 4	557361	2.6
DSV - 10 - M - 2.1/1/X/T200	DB 4	557362	2.6
DSV - 10 - M - 2.1/1/X/T210	DB 4	555408	2.6
DSV - 10 - M - 2.1/1/X/T315	DB 4	557363	2.6
DSV - 10 - M - 2.1/1/X/T330	DB 4	557364	2.6
DSV - 10 - EY - 2.0/1/X/XXXX - G24 - Z4	without DB 4	557366	3.6
DSV - 10 - EY - 2.1/1/X/T210 - G24 - Z4	DB 4	557365	3.8
DSV - 10 - M - 4.0/1/X/XXXX	without DB 12	555999	3.1
DSV - 10 - M - 4.1/1/X/T100	DB 12	555971	3.5
DSV - 10 - M - 4.1/1/X/T200	DB 12	555973	3.5
DSV - 10 - M - 4.1/1/X/T210	DB 12	555974	3.5
DSV - 10 - M - 4.1/1/X/T315	DB 12	555977	3.4
DSV - 10 - M - 4.1/1/X/T330	DB 12	555978	3.5
DSV - 10 - EY - 4.0/1/X/XXXX - G24 - Z4	without DB 12	557367	4.5
DSV - 10 - EY - 4.1/1/X/T100 - G24 - Z4	DB 12	555983	4.9
DSV - 10 - EY - 4.1/1/X/T200 - G24 - Z4	DB 12	555985	3.9
DSV - 10 - EY - 4.1/1/X/T210 - G24 - Z4	DB 12	555986	4.9
DSV - 10 - EY - 4.1/1/X/T315 - G24 - Z4	DB 12	555989	3.9
DSV - 10 - EY - 4.1/1/X/T330 - G24 - Z4	DB 12	555990	4.9

2.1.4 Type of construction

Ball valve isolating device

Pressure relief valve is a direct-acting cone poppet valve

Poppet valve is pilot-operated

2.1.5 Mounting position

Optional

2.1.6 Weight

See table 2.1.3

2.1.7 Flow direction

According to symbol

2.1.8 Ambient temperature

- 10 °C to + 80 °C

2.1.9 Materials

Housing and blanking plug

- Steel
- Surface protection: phosphate-plated

Ball

- Steel
- Hard-chromed

Pressure relief valve and poppet valve

Valve body:

- High tensile steel

Closing element:

- Hardened and polished steel
- Wear-resistant
- Surface protection: phosphate-plated

Ball seal

- High quality synthetic material (POM)

Soft seals

- Perbunan (NBR)

Clamped handle SW 09, cranked

- Red anodised aluminium

2.2. HYDRAULIC SPECIFICATIONS

2.2.1 Nominal pressure PN 350

2.2.2 Operating fluids

Mineral oil to DIN 51524 Part 1 and 2 (other fluids on request)

2.2.3 Temperature of operating fluid - 10 °C to + 80 °C

2.2.4 Viscosity range

min. 10 mm²/s
max. 380 mm²/s

2.2.5 Filtration

Max. permitted contamination level of the operating fluid to NAS 1638 class 10. We therefore recommend a filter with a minimum retention rate of $\beta_{20} \geq 100$. The fitting of filters and regular replacement of filter elements guarantees correct operation, reduces wear and tear and extends the service life.

2.2.6 Δp - Q Graph curve DSV - 10 with pressure relief valve DB 4

Measured at $v = 30 \text{ mm}^2/\text{s}$ and $t_{\text{oil}} = 50 \text{ }^\circ\text{C}$

Flow rate P → S

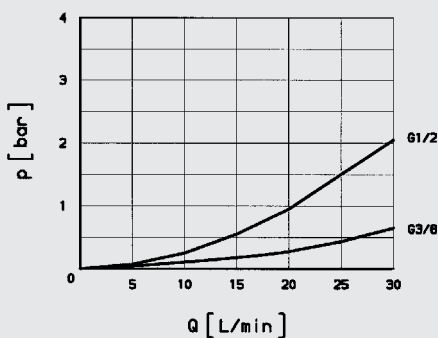

Flow rate S → T

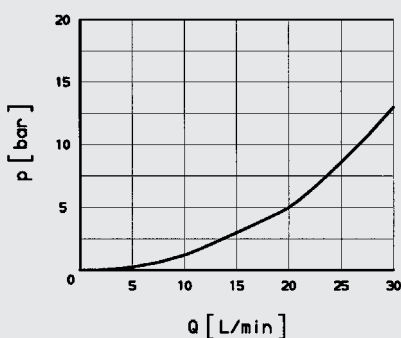

2.2.7 Δp - Q Graph curve DSV - 10 with pressure relief valve DB 12

Measured at $v = 30 \text{ mm}^2/\text{s}$ and $t_{\text{oil}} = 50 \text{ }^\circ\text{C}$

Flow rate P → S

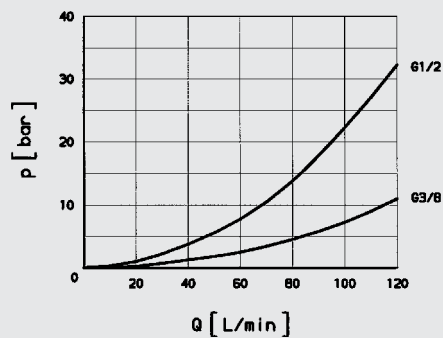

Flow rate S → T

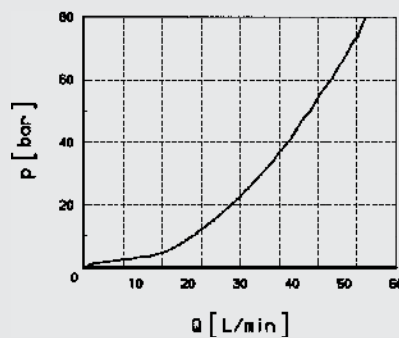

2.2.8 Pressure, dependent on flow rate DB 4

Measured at $v = 36 \text{ mm}^2/\text{s}$ and $t_{\text{oil}} = 50 \text{ }^\circ\text{C}$

Pressure range ...100 bar

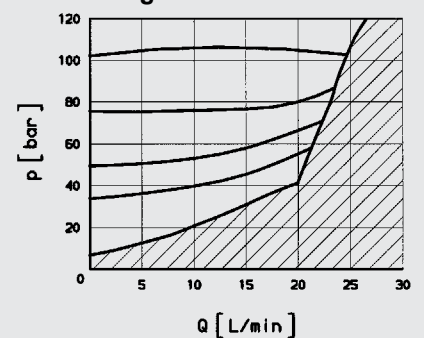

Pressure range ...200 bar

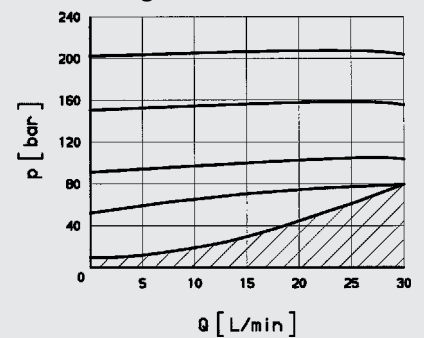

Pressure range ...350 bar

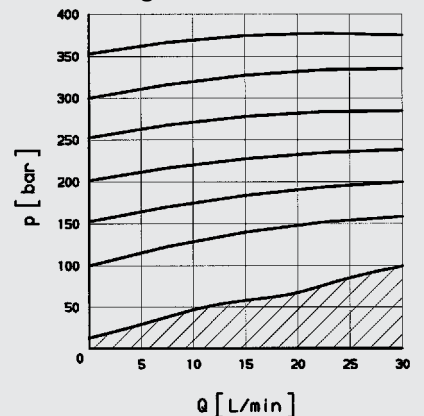

2.2.9 Pressure, flow rate dependent DB 4 - TÜV

Measured at $v = 36 \text{ mm}^2/\text{s}$ and
 $t_{\text{oil}} = 50 \text{ }^\circ\text{C}$

Application range of DB 4 - TÜV

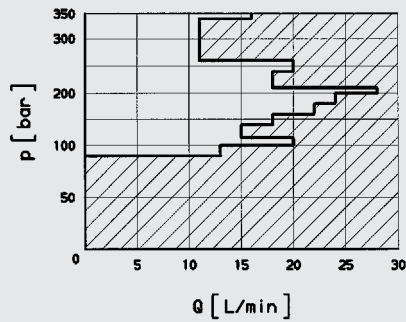

Q_{max} table for DB 4 - TÜV

Max. permitted flow rate of the pump

Q_{max} [l/min]	p [bar]
13	90 - 100
20	101 - 115
15	116 - 140
18	141 - 160
22	161 - 180
24	181 - 200
28	201 - 210
18	211 - 240
20	241 - 260
11	261 - 340
16	341 - 360

2.2.10 Pressure, dependent on flow rate DB 12

Measured at $v = 28 \text{ mm}^2/\text{s}$ and
 $t_{\text{oil}} = 50 \text{ }^\circ\text{C}$

Pressure range ...150 bar

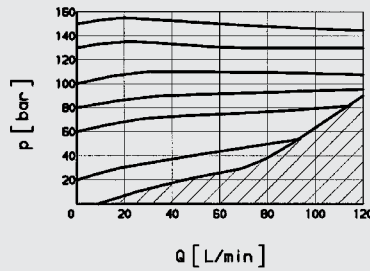

Pressure range ...250 bar

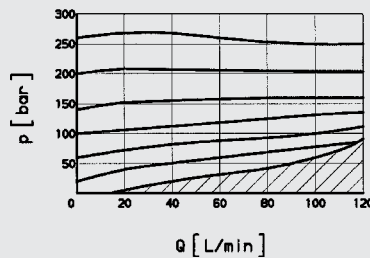

Pressure range ...350 bar

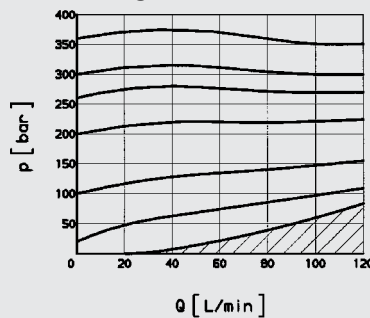

Application range of DB 12 - TÜV

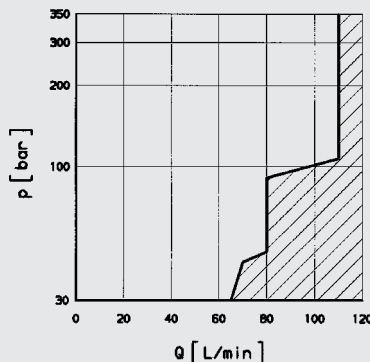

Q_{max} table for DB 12 - TÜV

Max. permitted flow rate of the pump

Q_{max} [l/min]	p [bar]
65	30, 35
72	40, 45
80	50, 60, 70, 80, 90
95	100
110	110, 120, 140, 160... to 400

Note:

This valve cannot be set to values in the shaded areas.

2.3. TYPE OF OPERATION

2.3.1 Type of construction

Solenoid-operated by means of pressure-tight, oil-immersed, single-stroke solenoids in accordance with VDE 0580.

Actuating solenoid with male connector to DIN 43650, standard for general industrial applications, available for 24 V DC and 230 V AC.

2.3.2 Type of voltage

DC solenoid (type G)
When connected to AC voltage (type W) the necessary DC voltage is produced by means of a bridge rectifier connector.

2.3.3 Nominal voltage

Standard nominal voltages :
Voltage type G : 24 V
Voltage type W : 230 V

2.3.4 Voltage tolerance

- 5 %
+ 10 %

2.3.5 Nominal current

Dependent on the nominal voltage
G 24 V : 1.04 A
W 230 V : 0.13 A

2.3.6 Power consumption

$p_{20} = 26 \text{ W}$

2.3.7 Duty cycle

100% = continuous operation

2.3.8 Switching time

Depending on the symbol, pressure across the individual ports and flow rate, switch-on time is approx. 25 ms, switch-off time approx. 35 ms.

2.3.9 Protection class

Protection class IP 65 to DIN 40050 provided connector has been fitted correctly.

2.3.10 Ambient temperature range

- 10 °C to + 40 °C

3. ADAPTERS

3.1. GENERAL

Adapters for mounting different makes and systems of accumulator must be ordered separately.

3.2. MODEL CODE

(also order example)

UEBERG-ST - S30 - NBR

Adapter _____

Type _____

S10 = M 33 x 2 / G 3/4 A

S11 = M 33 x 2 / G 1 A

S12 = M 33 x 2 / G 1 1/4 A

S13 = M 33 x 2 / G 2 A

S20 = M 33 x 2 / M 30 x 1.5

S21 = M 33 x 2 / M 40 x 1.5

S22 = M 33 x 2 / M 50 x 1.5

S30 = M 33 x 2 / G 1/2 A

S31 = M 33 x 2 / G 3/4 A

S32 = M 33 x 2 / G 1 A

S33 = M 33 x 2 / G 1 1/4 A

(M 20 x 1.5 / ... on request)

Seal _____

NBR = Perbunan

When ordering, please quote part number (see Table 3.3.)

Delivery is longer for non-standard models.

3.3. STANDARD MODELS

Adapter / Type	Order No. = Part No.
ADAPTER - S10 - NBR	369479
ADAPTER - S11 - NBR	372750
ADAPTER - S12 - NBR	369480
ADAPTER - S13 - NBR	369481
ADAPTER - S20 - NBR	369482
ADAPTER - S21 - NBR	369483
ADAPTER - S22 - NBR	369484
ADAPTER - S30 - NBR	369485
ADAPTER - S31 - NBR	369486
ADAPTER - S32 - NBR	369487
ADAPTER - S33 - NBR	379009

3.4. DIMENSIONS OF ADAPTERS

Adapter - M 33 x 2, Figure 1

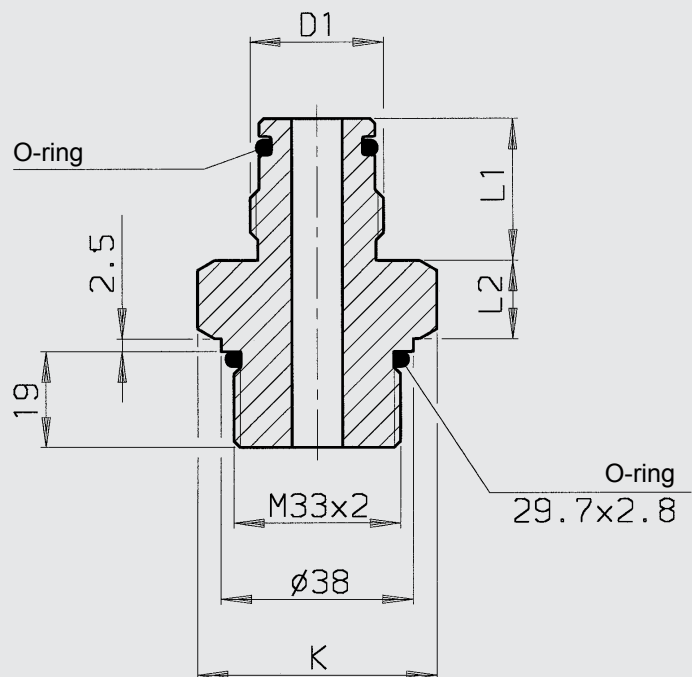

Type	Thread D1	D2	L1	L2	K	O-ring
S10	ISO 228 - G ¼ A	-	28	15.5	SW 41	17 x 3
S11	ISO 228 - G 1 A	-	34	16.5	SW 46	22 x 3
S12	ISO 228 - G 1¼ A	-	37	16.5	SW 46	30 x 3
S13	ISO 228 - G 2 A	-	44	20.5	SW 65	48 x 31

Adapter - M 33 x 2, Figure 2

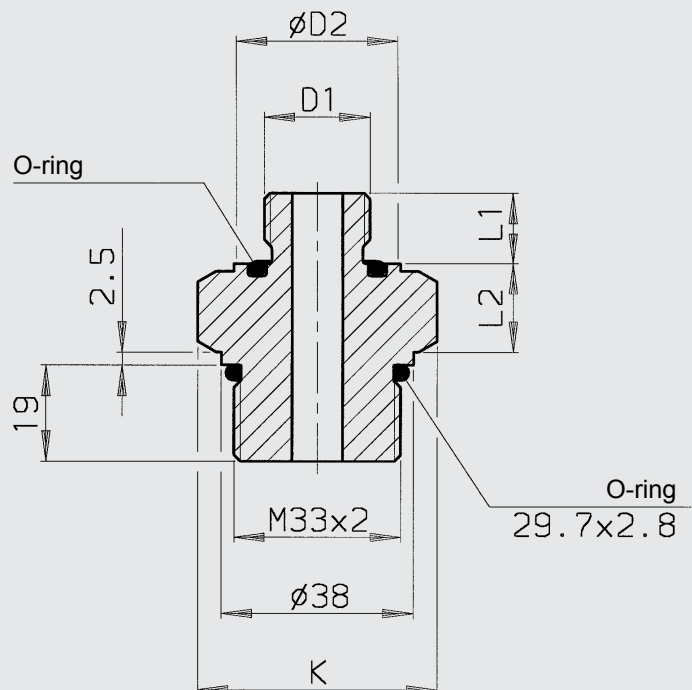

Type	Thread D1	D2	L1	L2	K	O-ring
S20	M 30 x 1.5	40	15	17.5	SW 41	32 x 2
S21	M 40 x 1.5	54	20	20.5	SW 55	43 x 3
S22	M 50 x 1.5	64	20	20.5	SW 65	53 x 3
S30	ISO 228 - G ½ A	33	14	17.5	SW 41	22 x 3
S31	ISO 228 - G ¾ A	40	16	17.5	SW 41	28 x 3
S32	ISO 228 - G 1 A	45	18	18.5	SW 46	35 x 3
S33	ISO 228 - G 1¼ A	55	20	18.5	SW 65	44 x 33

4. DIMENSIONS

DSV - 10 - M - 2.1/1/X/....

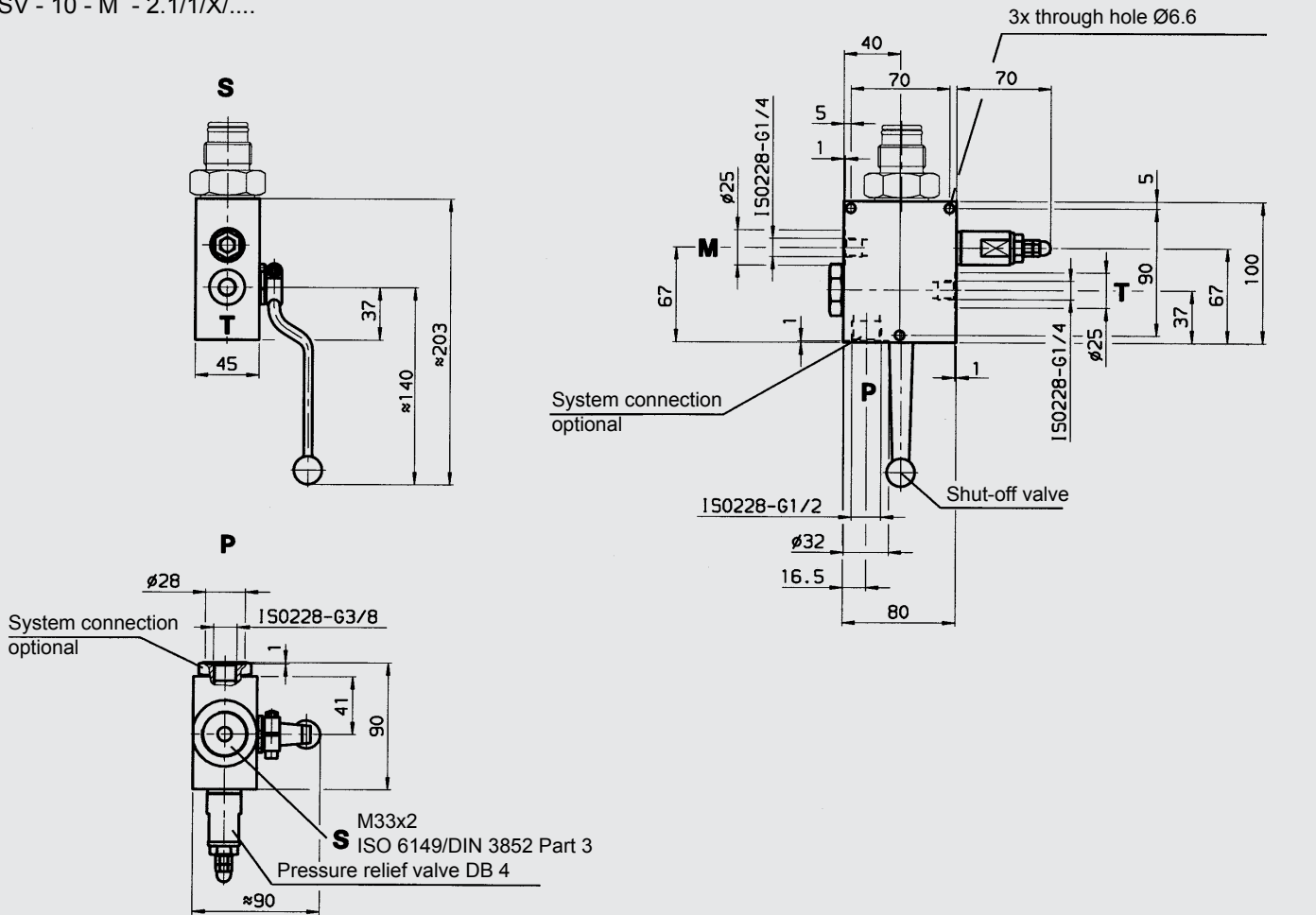

DSV - 10 - E.- 2.1/1/X/....

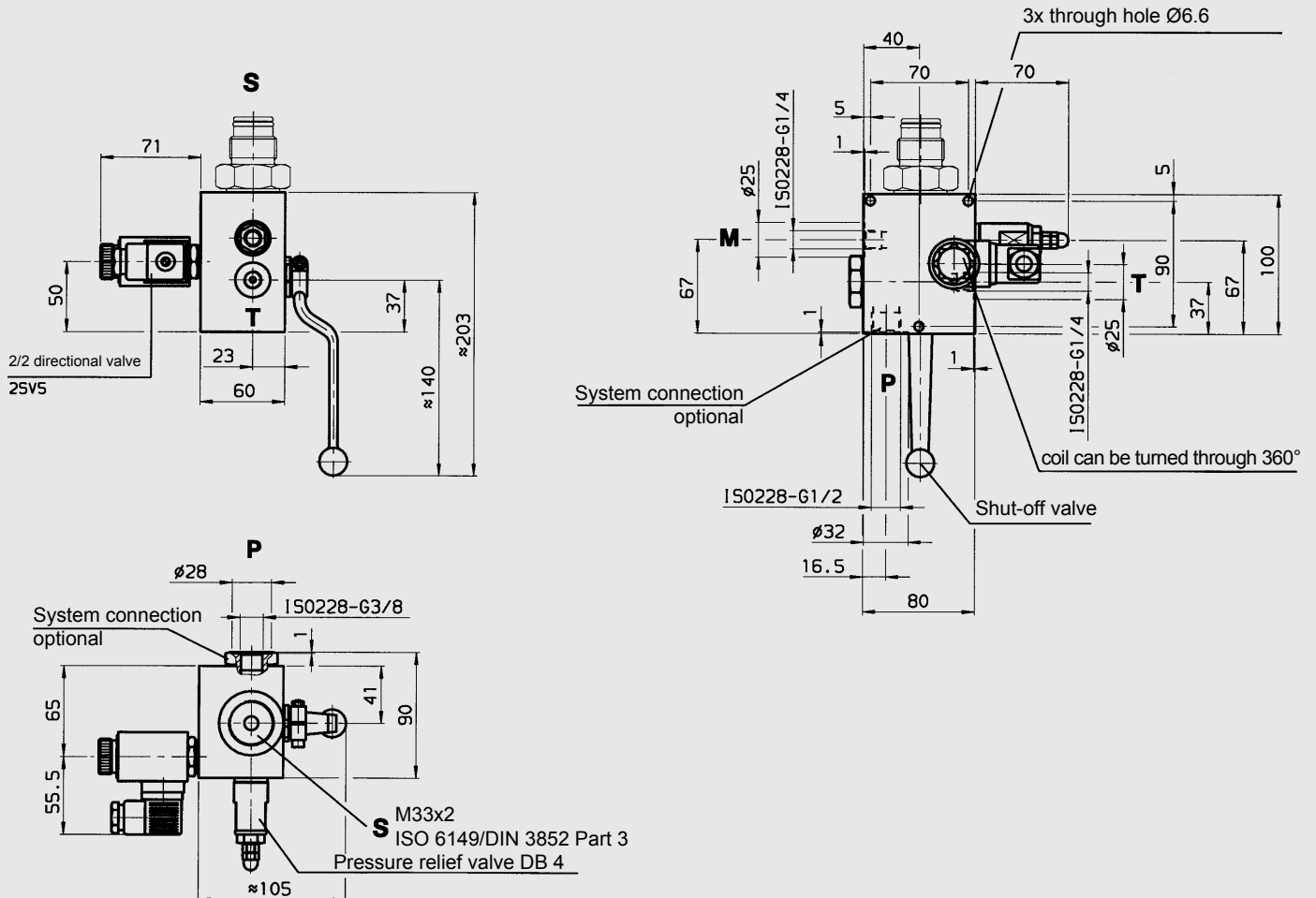

5. SPARE PARTS

(Seal kit)

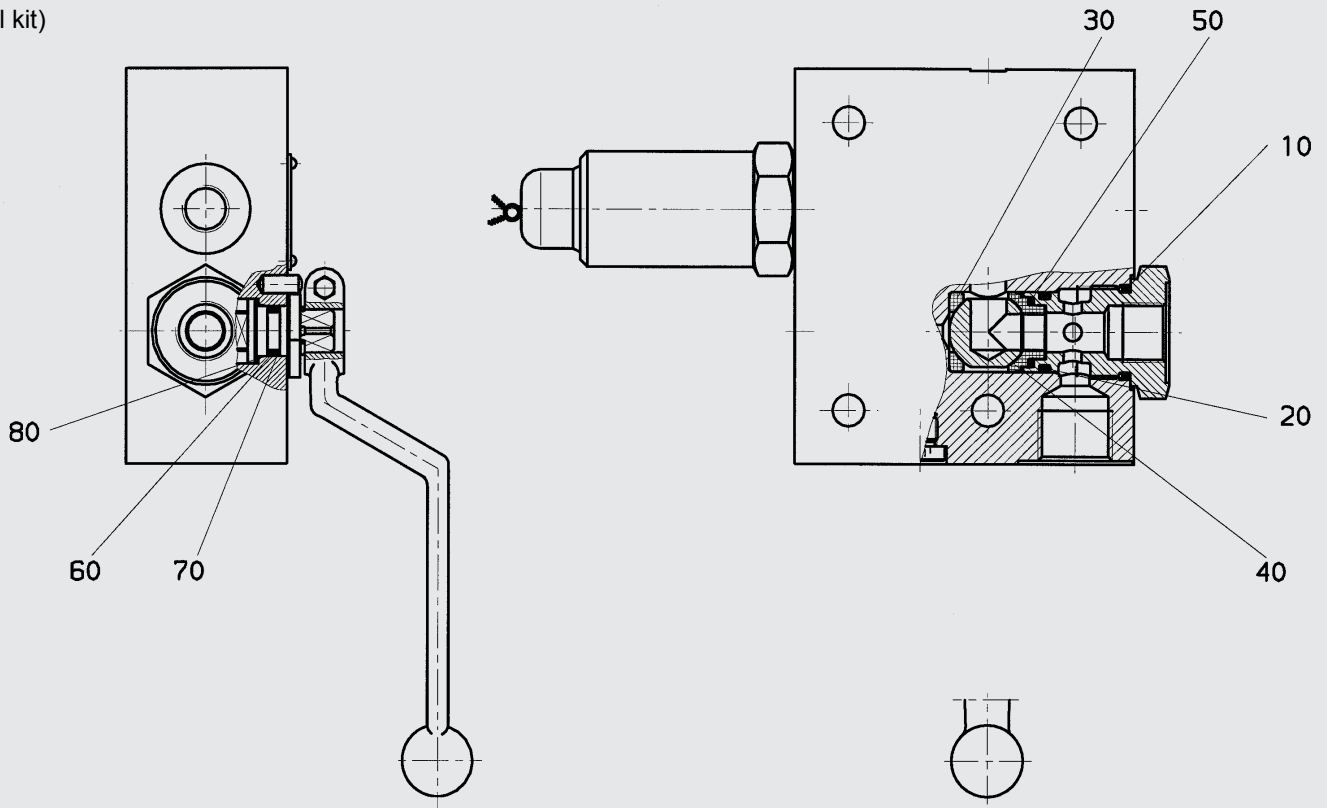

The parts indicated by numbers in the above drawing are contained in the seal kit.

Seal kit	Order No. = Part No.
DSV - 10	702513
DB 4	715870
DB 12	557399
2 SV 5	480078

NOTE

The information in this brochure relates to the operating conditions and applications described.

For applications and operating conditions not described, please contact the relevant technical department.

Subject to technical modifications.

HYDAC Accessories GmbH
Hirschbachstr. 2
66280 Sulzbach/Saar
Tel.: +49 (0)6897 - 509-01
Fax: +49 (0)6897 - 509-1009
Internet: www.hydac.com
Email: info@hydac.com

